

IA2410 High Voltage, High-Side Current Sense Amplifier

DESCRIPTION

The IA2410 is a uni-directional, high voltage high-side current sense amplifier for use in portable PCs, cellular infrastructure equipment, high-end routers, smart battery packs, automotive applications, and other power management applications that require current monitoring and current control loops. The IA2410 is designed to be an extremely cost-effective, value-added current sense amplifier that has low power requirements, can sense a wide-range of currents with different resistor values, and is available in a compact 5-pin SOT-23 or 8-pin SOIC package.

The IA2410 measures the voltage drop across a sense resistor in the high voltage side of a line. Large values of current can be measured by using a small resistor value and keeping the series voltage drop low across the sense resistor. The IA2410 operates from a single supply +5V to +36V and has a current output that can be converted to a ground referenced voltage with a resistor R_{OUT} . The amplification factor of the current sense can be adjusted with a choice of external resistor ratios. A special feature of the IA2410 is the provision of an output voltage which is proportional to ambient temperature. This can be used for compensating the temperature coefficient of the sense resistor, thus allowing the possibility of using a PCB trace as an inexpensive sense resistor.

FUNCTIONAL BLOCK DIAGRAM

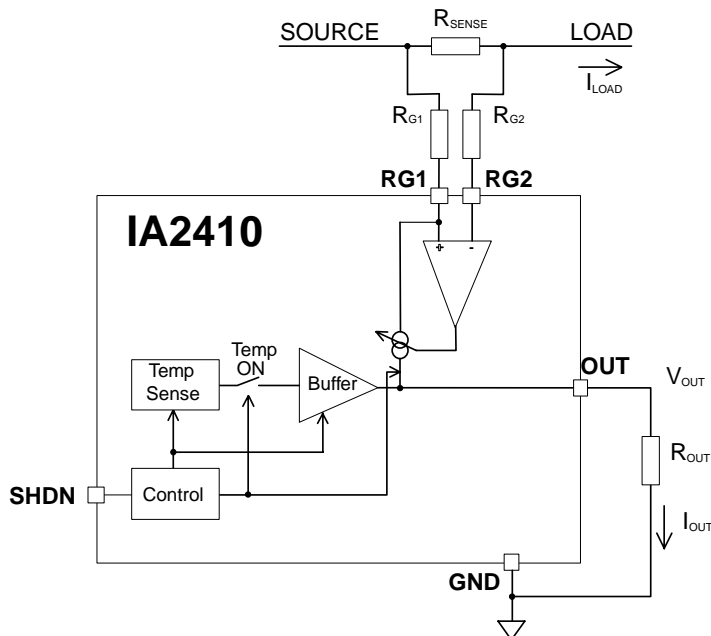

IA2410

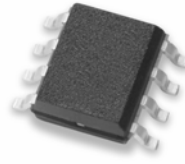

8-pin SOIC



5-pin SOT-23

PIN ASSIGNMENT

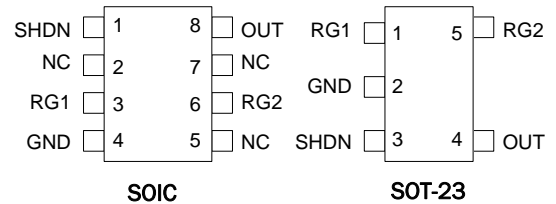

See back page for ordering information.

FEATURES

- Complete, uni-directional high side current sense capability
- Internal temperature sensor
- Output option for temperature measurement
- 0.2% Full scale accuracy
- +5V to +36V supply operation
- 90µA Max supply current
- 9µA Shutdown current
- Operating Temperature Range : -40°C to +85°C
- 85dB power supply rejection
- 5-pin SOT-23 or 8-Pin SOIC package

TYPICAL APPLICATIONS

- Battery chargers
- DC motor control
- Smart battery packs
- Backup systems
- Current control applications

DETAILED DESCRIPTION

The IA2410 high-side current sense amplifier features a +5V to +36V input common-mode range without need for an additional supply pin, since the input pins RG1 and RG2 provide the necessary supply voltage. Referring to the Circuit Block Diagram, the IA2410 operation can be described as follows:

Current flowing from the voltage source creates a voltage drop, V_{SENSE} , across resistor R_{SENSE} . Because the current flowing through R_{G2} is negligible compared current I_{LOAD} , the sense amplifier inverting-input voltage, V_{RG2} , at pin RG2 is approximately

$$V_{RG2} = V_{SOURCE} - (I_{LOAD} * R_{SENSE})$$

The amplifier's open-loop gain forces its non-inverting input, pin RG1, to the same voltage as the inverting input so the drop across R_{G1} equals $I_{LOAD} * R_{SENSE}$. The op-amp input bias currents are very small and equal so:

$$I_{LOAD} * R_{SENSE} = I_{OUT} * R_{G1}$$

$$I_{OUT} = I_{LOAD} * R_{SENSE} / R_{G1}$$

The output current can be converted to a ground-referred output voltage, V_{OUT} , using R_{OUT}

$$V_{OUT} = I_{LOAD} * R_{SENSE} * R_{OUT} / R_{G1}$$

Temperature Sensing Feature

The current sense amplifier has very low input offset temperature drift. If external resistors R_{SENSE} , R_{OUT} , R_{G1} , and R_{G2} have low temperature coefficients, the total system will show very little temperature dependence. However, if the sense resistor has a high temperature coefficient, such as a low-cost PCB copper trace, variations in temperature can degrade the overall accuracy of the system. To address this problem a voltage proportional to the temperature of the die can be obtained under micro-controller control. By periodically reading the temperature, the micro-controller can compensate for the changes in gain with temperature. The equation describing output voltage as a function of temperature is of the form:

$$V_{OUT}(T) = (kT/q)(25)[\ln(9)]$$

$$k = \text{Boltzmann's constant} = 1.381 \times 10^{-23}$$

$$T = \text{temperature in degrees Kelvin}$$

$$q = \text{electron charge} = 1.6 \times 10^{-19}$$

Example to illustrate a potential advantage of the temperature feature:

$$\begin{aligned} \text{Gain} &= I_{OUT} / I_{LOAD} \text{ or } \text{Gain} = V_{OUT} / I_{LOAD} \\ &= (I_{LOAD} * R_{SENSE} / R_{G1})(1 / I_{LOAD}) = (R_{SENSE})(R_{OUT}) / R_{G1} \\ &= R_{SENSE} / R_{G1} \end{aligned}$$

Assume: The temperature of R_{SENSE} and the die track within 7°C (note 1)

$$R_{SENSE}: T_c = 0.4\% / ^\circ\text{C} \text{ (PCB trace)}$$

$$T_a: -40^\circ\text{C} \text{ to } +85^\circ\text{C} \Rightarrow T_a = 22.5^\circ\text{C} \pm 62.5^\circ\text{C}$$

$$\text{Then: } \Delta R_{SENSE} / R_{SENSE} = (0.4\%)(\pm 62.5^\circ\text{C}) = \pm 25\%$$

Without temperature compensation:

$$\text{Gain} = \pm 25\% \text{ because } \Delta R_{SENSE} = \pm 25\%$$

With temperature compensation:

$$G_{eff} = (\pm 7^\circ\text{C})(0.4\% / ^\circ\text{C}) = \pm 2.8\%$$

G_{eff} , the effective gain, is adjusted in the micro-controller based on die temperature.

Note 1: Contributors to the assumed 7°C difference in temperature between the die and R_{SENSE} include the accuracy with which the micro-controller can convert the die temperature voltage to a digital number, the thermal coefficients from junction to package and package to ambient and location of the die relative to R_{SENSE} .

Temperature Sensing Operation

To obtain a voltage proportional to absolute temperature (V_{TEMP}) at the current sense output, a burst of 3 pulses is sent to the SHDN pin. The sequence and actual timing is summarized in Figure 1. The pulses should be high for more than T_{HIGH} and low for less than T_{LOW} . At the rising edge of the third pulse an internal signal Temp_ON becomes high and enables V_{TEMP} at the output. The V_{TEMP} is available at the output for the time T_{ON} . The output can be read (sampled) after the time T_{START} , when it is guaranteed that all internal switching is disabled and the output voltage (V_{TEMP}) is settled. After the time T_{ON} the chip is automatically switched back to the current sensing mode.

When the part is alternatively used in the shut-down mode (low current consumption) and in the current sensing mode (normal mode) the time in between adjacent shut down pulses must be at least T_{SENSE} to avoid the current sense going into the temperature measurement mode after the sequence of 3 shut-down pulses.

Temperature Sensing Operation, continued

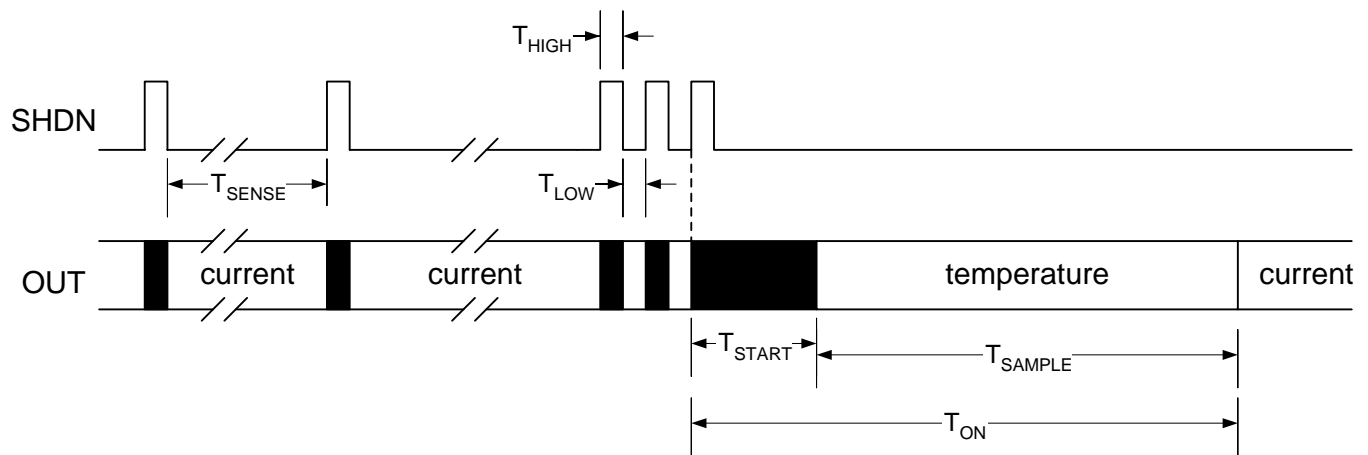

Fig. 1: Temperature measurement sequences

Parameter	Symbol	Note	Limit			Units
			Min	Typ	Max	
The width of pulse high to go to the temperature measurement mode	T_{HIGH}		1			μs
The width of pulse low to go to the temperature measurement mode	T_{LOW}		2		20	μs
Time between adjacent SHDN pulses not to go to the temperature measurement mode	T_{SENSE}		100			μs
Time during which the temperature is available at the output.	T_{ON}		200		1000	μs
Settling time for temperature output V_{TEMP}	T_{START}				50	μs

GENERAL DEVICE SPECIFICATIONS

Absolute Maximum Ratings

Parameter	Value	Unit
Voltage at RG1, RG2, SHDN to GND	-0.3 to +40	V
Differential Input Voltage, RG1 to RG2	±0.3	V
Voltage at OUT	-0.3 to +8	V
Current into SHDN, GND, OUT, RG1, RG2	±50	mA
Continuous Power Dissipation ($T_A = +70\text{ }^\circ\text{C}$) 8-pin SOIC derate 5.88 mW/°C above +70°C (note 1) 5-pin SOT23 derate 7.1 mW/°C above +70°C (note 1)	471 571	mW mW
Operating Temperature Range	-40 to +125	°C
Junction Temperature, T_{JMAX}	up to +150	°C
Storage Temperature	-65 to +160	°C

Note 1: The device is mounted on a standard PCB with a 100mm² copper foil connected to the GND pin, no airflow. When stressed beyond the “Absolute Maximum Ratings,” permanent damage to the device may occur and prolonged use at the absolute maximum ratings may affect reliability. It is recommended that the device operate within the limits indicated in the Electrical Specifications which follow.

ELECTRICAL SPECIFICATION

Unless otherwise specified: $V_{RG1} = +5V$ to $+36V$, $RG1 = RG2 = 200\Omega$, $V_{SENSE} = 0V$, $T_A = +25^\circ C$

DC and AC Characteristics

Parameter	Symbol	Test Condition	Min	Typ	Max	Units
Operating Voltage	V_{RG1}		5		36	V
Total Input Current	$I_{RG1}+I_{RG2}$	$I_{LOAD} = 0A$		46	90	μA
Input Currents	I_{RG1}, I_{RG2}	$I_{LOAD} = 0A$		23	45	μA
Input Current Matching	I_{OS}	$I_{RG1} - I_{RG2}$		± 0.4	± 1.5	μA
Sense Voltage (Note 1)	V_{SENSE}			100		mV
OUT Current Accuracy	I_{RG}/I_{OUT}	$V_{SENSE} = 100mV$		± 0.2	± 1	%
No-Load OUT Error		$V_{RG1} = 10V, V_{SENSE} = 0V$		0.5	5.0	μA
Low-Level OUT Error		$V_{RG1} = 10V, V_{SENSE} = 3mV$		± 0.5	± 5.0	μA
Power-Supply Rejection	PSR	$V_{SENSE} = 100mV$		-85		dB
Shutdown Supply Current	$I_{RG1}+I_{RG2}$	$V_{SHDN} = 2.4V$		3.5	9	μA
SHDN Input Low Voltage	V_{IL}				0.3	V
SHDN Input Low Current	I_{IL}	$V_{SHDN} = 0V$			1.0	μA
SHDN Input High Voltage	V_{IH}		2.4			V
SHDN Input High Current	I_{IH}	$V_{SHDN}=2.4V$			1.0	μA
OUT Output Voltage Range	V_{OUT}	V_{OUT} clamped at 8 V	0		$V_{RG1} - 3.5$ (<8)	V
OUT Output Resistance (Internal)		$I_{OUT} = 1.5mA$	1	3		M
OUT Rise, Fall Time		$V_{SENSE} = 5mV$ to $150mV$, $R_{OUT} = 2k\Omega$, $C_{OUT} = 50pF$, 10% to 90% (Note 2)		0.4 0.5		μs μs
OUT Settling Time to 1% of Final Value		$V_{SENSE} = 5mV$ to $150mV$, $R_{OUT} = 2k\Omega$, $C_{OUT} = 50pF$ (Note 2)		1 2		μs μs
Maximum Output Current	I_{OUT}	For $I_{OUT} > 1.5 mA$ the internal current limitation starts to limit the output current	1.5		10	mA
Temperature Output Error		$V_{RG1} = 12V$		± 2		$^\circ C$

All devices are 100% production tested at $T_A = +25^\circ C$. The $-40^\circ C$ to $+85^\circ C$ temperature limits are guaranteed by design.

Note 1: V_{SENSE} is the voltage across the sense resistor.

Note 2: C_{OUT} is the load capacitance seen by the OUT pin.

TYPICAL PERFORMANCE DATA

Supply current vs. supply voltage

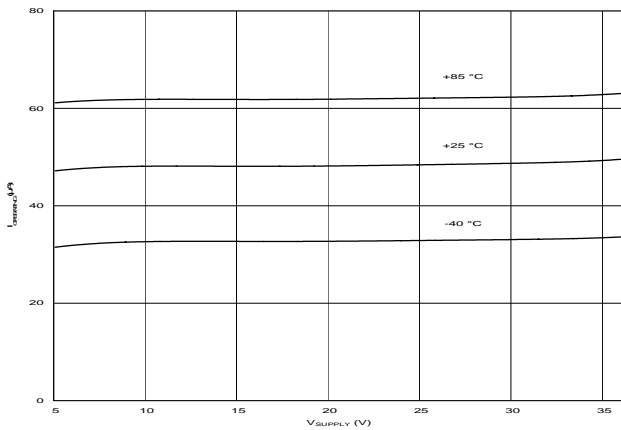

Shutdown supply current vs. supply voltage

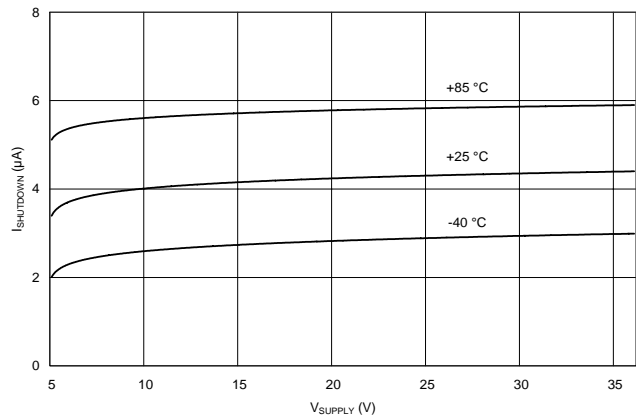

Transient response 1

(R_{OUT} = 2 KΩ, C_{OUT} = 50 pF, R_{G1} = R_{G2} = 200 Ω)

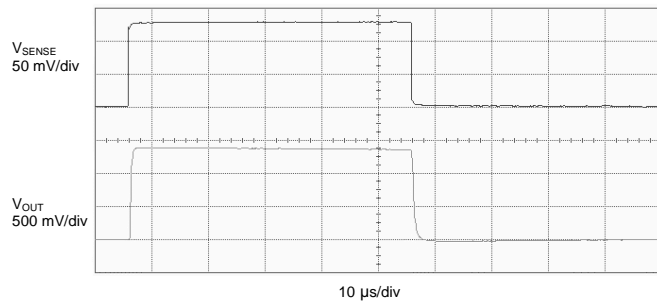

Transient response 2

(R_{OUT} = 1 KΩ, C_{OUT} = 50 pF, R_{G1} = R_{G2} = 10 Ω)

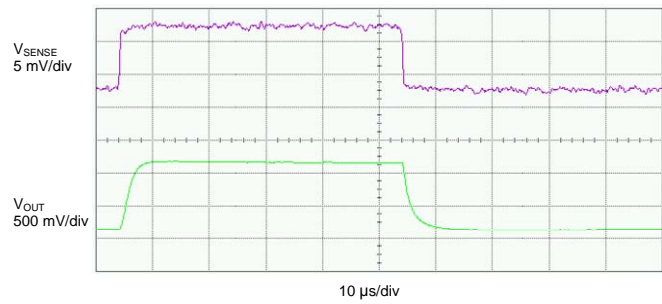

TYPICAL PERFORMANCE DATA

Startup delay

($R_{OUT} = 2\text{ K}\Omega$, $C_{OUT} = 50\text{ pF}$, $R_{G1} = R_{G2} = 200\ \Omega$, $V_{SENSE} = 100\text{ mV}$)

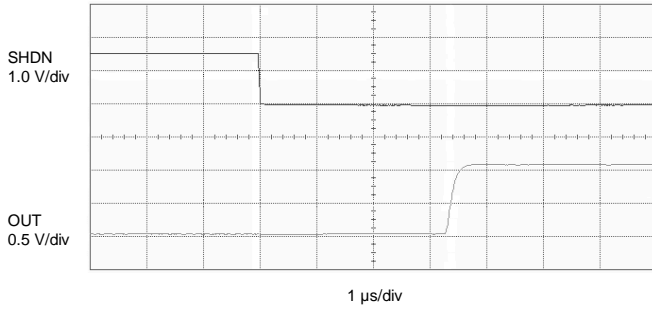

Output error vs. supply voltage

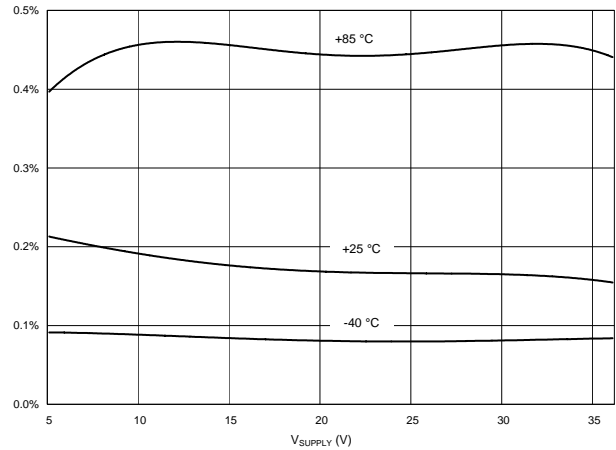

Output error vs. temperature

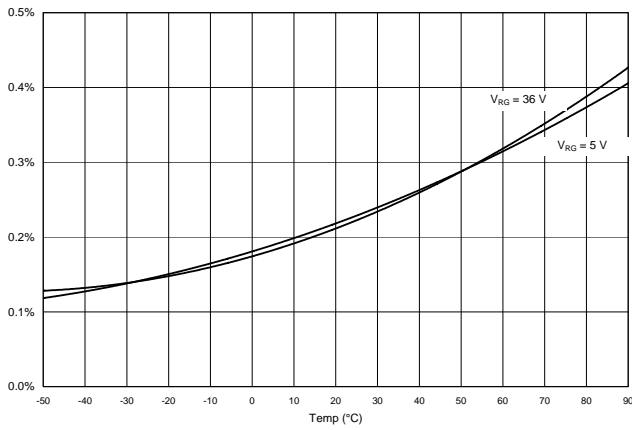

Output error vs. sense voltage

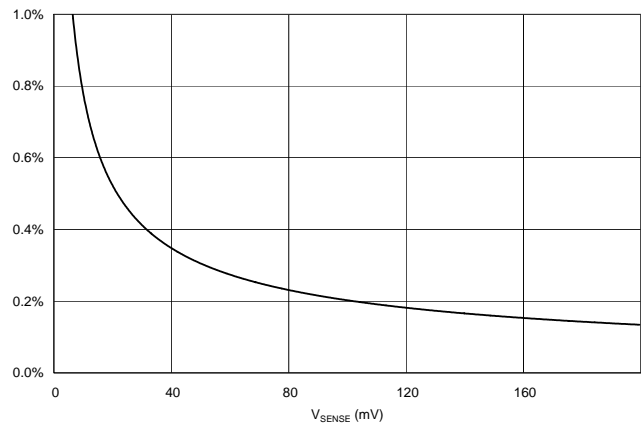

TYPICAL APPLICATION

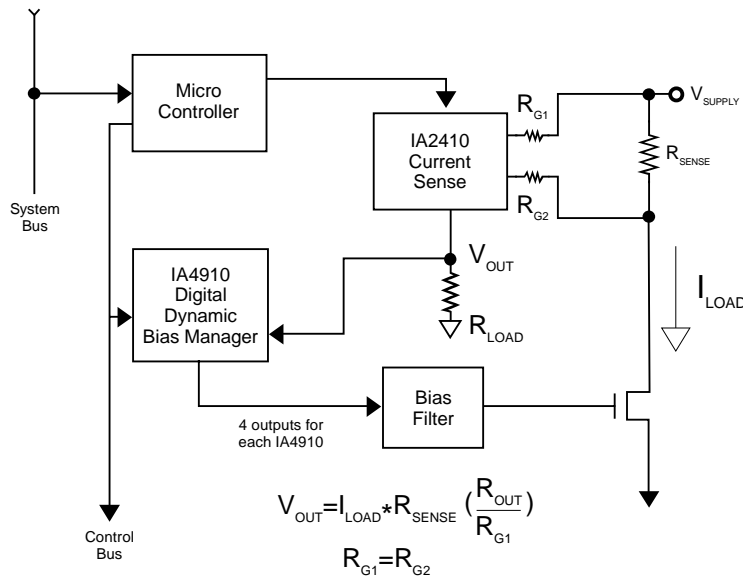

Fig. 2: Connecting the IA2410 in a power control application

APPLICATION HINTS

The IA2410 can sense a wide range of currents with different sense resistor values. See below for some typical operation values.

Full-scale load current I_{SENSE} (A)	Current-sense resistor R_{SENSE} (mΩ)	Gain-setting resistors, $R_{G1}=R_{G2}$ (Ω)	Output resistor, R_{OUT} (kΩ)	Full-scale output voltage, V_{OUT} (V)	Scale factor V_{OUT}/I_{SENSE} (V/A)	Typical error at 1, 10 and 100% of full load (%)		
						1%	10%	100%
0.1	1000	200	5	2.5	25	10	1	0.2
1	100	200	5	2.5	2.5	10	1	0.2
5	20	100	2	2	0.4	5	1	0.2
10	5	50	2	2	0.2	5	1	0.4

Selecting R_{SENSE}

The selection of R_{SENSE} is a trade-off based on the following, sometimes contradictory, criteria: To minimize voltage loss, use a low R_{SENSE} value. On the other hand, to obtain maximum accuracy for lower currents, choose a high value for R_{SENSE} because offsets become less significant with a larger sense voltage. Another criteria can be power dissipation. The sense resistor should be able to dissipate power losses. If the resistor's rated power dissipation is exceeded, its value may drift or it can fail, possibly resulting in a differential voltage across terminals RG1 and RG2 that exceeds the absolute maximum ratings of the device. R_{SENSE} should be low inductance to reduce the impact of any high frequency components in the current being measured. Low inductance metal film resistors are available for applications where this is a concern.

The IA2410 requires at least 3.5V of voltage headroom between the voltage at pin RG1 and pin OUT. As V_{SENSE} becomes large, the drop across R_{G1} increases further limiting the voltage headroom.

$$\begin{aligned}
 V_{OUTmax} &= V_{RG1} - 3.5V \\
 &= V_{SOURCE} - V_{SENSE} - 3.5V \\
 &= V_{SOURCE} - (I_{LOAD} * R_{SENSE}) - 3.5V \\
 R_{SENSEmax} &= (V_{SOURCE} - V_{OUTmax} - 3.5V) / I_{LOAD}
 \end{aligned}$$

Selecting R_{G1} and R_{G2}

R_{G1} and R_{G2} are chosen to define the current-gain which equals R_{SENSE} / R_G where R_G=R_{G1}=R_{G2}. The minimum value of R_G is limited by input resistance, approximately 0.2Ω for the bond wires in the package plus the resistance of the traces on the card and by the maximum output current of the chip, 1.5 mA. As R_G is reduced, the input resistance becomes a larger portion of the total gain-setting resistance. For example for the lowest suggested value of R_G, 50Ω, a 0.2Ω input resistance will cause a 0.4 % difference in gain. This gain error can be compensated by trimming R_G or R_{OUT}. The maximum output current results in the following equation:

$$R_{Gmax} = V_{SENSEmax} / 1.5mA$$

For a given V_{SENSE}, as R_G decreases, I_{OUT} increases. Power is dissipated in R_{OUT} rather than going to the load reducing efficiency.

The input current, I_{RG1,2}, and input current mismatch, I_{OS}, together with R_G affects the full scale error as follows :

$$Error [\%] = \{ [(R_{G1} - R_{G2}) * I_{RG1,2} + (R_G * I_{OS})] / V_{SENSEfullscale} \} * 100$$

For example,

$$If R_{G1} = R_{G2} = 200 \Omega, \pm 1\%$$

$$I_{RG1,2} = 45 \mu A,$$

$$I_{OS} = 1.5 \mu A$$

Then Error [%] =

$$\{ [(4 \Omega * 45 \mu A) + (200 \Omega * 1.5 \mu A)] / 100mV \} * 100 = 0.48 \%$$

The error can be reduced by lowering the values of R_{G1}, R_{G2} and/or lowering their tolerances and by increasing V_{SENSE} (increase R_{SENSE}).

Choosing R_{OUT}

R_{OUT} can be chosen to obtain the required full-scale output voltage for the full scale I_{OUT} determined by R_{G1}, R_{G2} and R_{SENSE}.

$$\begin{aligned}
 R_{OUT} &= V_{OUTfullscale} / I_{OUT} \\
 &= (V_{OUTfullscale} * R_{G1}) / (I_{LOAD} * R_{SENSE})
 \end{aligned}$$

The upper limit of R_{OUT} is determined by the input impedance of the device that it drives. This input impedance should much larger than R_{OUT} otherwise the measurement accuracy will be degraded.

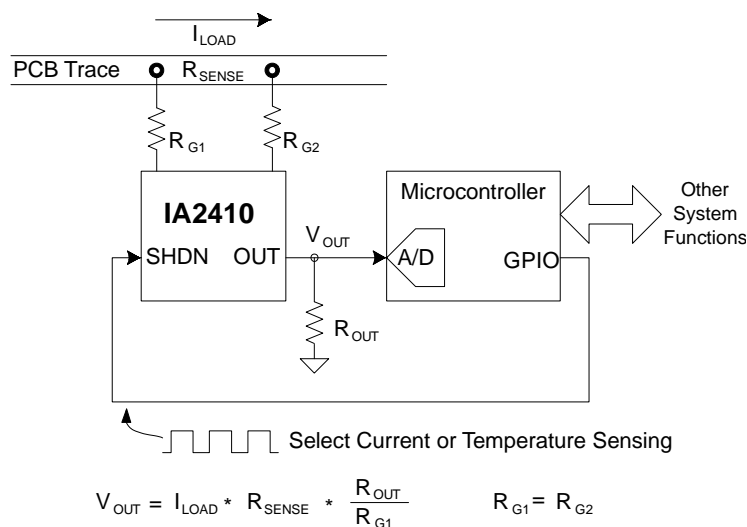
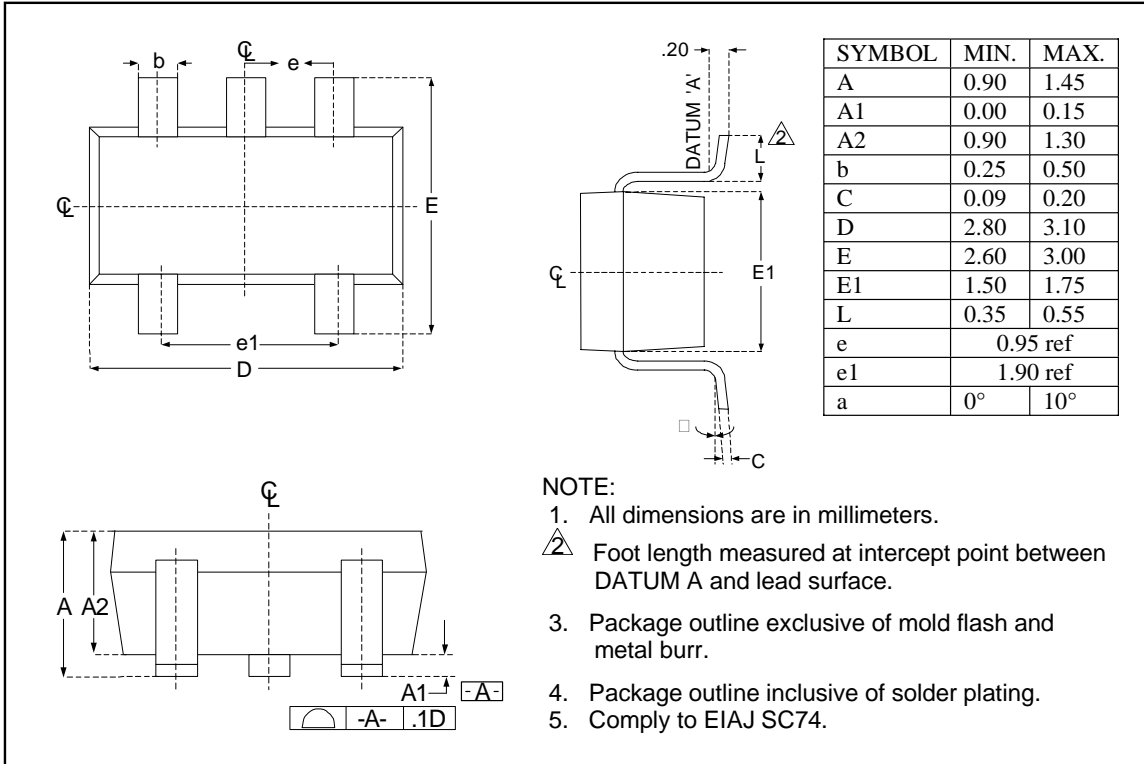

Fig. 3: Using the IA2410 internal temperature sensor to compensate for PCB trace resistance change over temperature

PACKAGE INFORMATION

5-Pin SOT-23



8-Pin SOIC

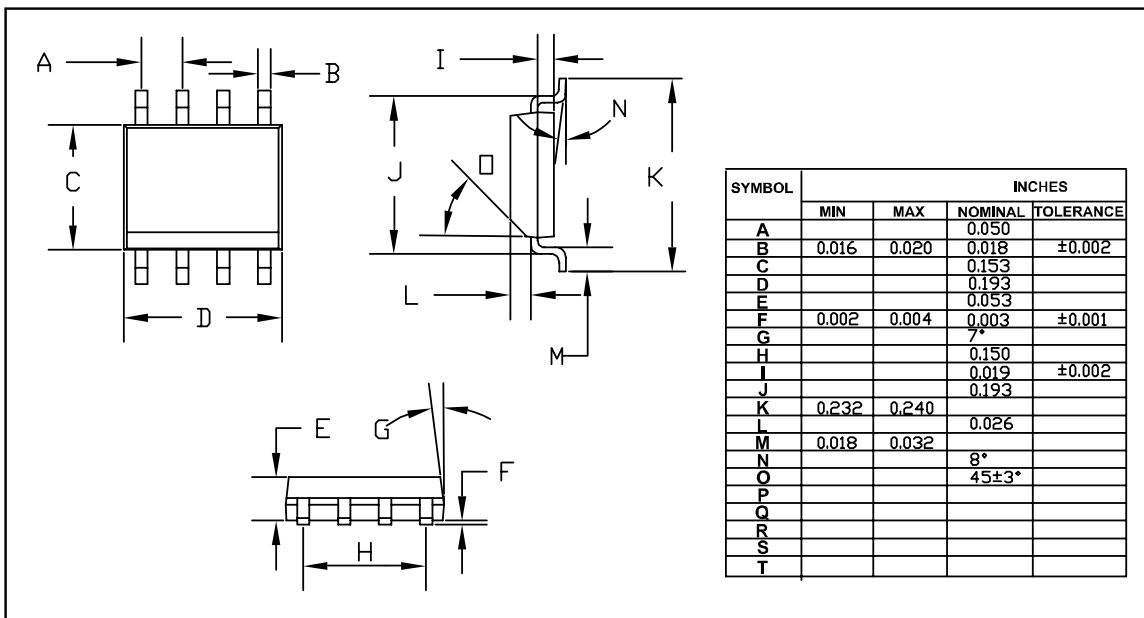

RELATED PRODUCTS AND DOCUMENTS

IA2410 High Voltage, High-Side Current Sense Amplifier

DESCRIPTION	ORDERING NUMBER
IA2410 8-pin SOIC	IA2410-IC CB8 Revision #
IA2410 5-pin SOT23	IA2410-IC CA5 Revision #
die	see Integration Associates

Related Resources

DESCRIPTION	ORDERING NUMBER
IA4910 Digital Dynamic Bias IC Product Brief	IA4910-PB
IA4910 Digital Dynamic Bias IC Datasheet	IA4910-DS
Programmable, Dynamic Biasing of LDMOS Application Note	IA4910-AN1

Note: Volume orders must include chip revision to be accepted.

Integration Associates, Inc.
 110 Pioneer Way, Unit L
 Mountain View, California 94041
 Tel: 650.969.4100
 Fax: 650.969.4582
 www.integration.com
 marketing@integration.com
 power.support@integration.com
 P536

The specifications and descriptions in this document are based on information available at the time of publication and are subject to change without notice. Integration Associates assumes no responsibility for errors or omissions, and disclaims responsibility for any consequences resulting from the use of information included herein. Additionally, Integration Associates assumes no responsibility for the functioning of un-described features or parameters. Integration Associates reserves the right to make changes to the product and its documentation at any time. Integration Associates makes no representations, warranties, or guarantees regarding the suitability of its products for any particular purpose and does not assume any liability arising out of the application or use of any product or circuit, and specifically disclaims any and all liability for consequential or incidental damages arising out of use or failure of the product. Nothing in this document shall operate as an express or implied license or indemnity under the intellectual property rights of Integration Associates or third parties. The products described in this document are not intended for use in implantation or other direct life support applications where malfunction may result in the direct physical harm or injury to persons. NO WARRANTIES OF ANY KIND, INCLUDING BUT NOT LIMITED TO, THE IMPLIED WARRANTIES OF MERCHANTABILITY OR FITNESS FOR A PARTICULAR PURPOSE, ARE OFFERED IN THIS DOCUMENT.

©2007 Integration Associates, Inc. All rights reserved. Integration Associates is a trademark of Integration Associates, Inc. All other trademarks belong to their respective owners.